



Hi-Lo Combi Valve (BALEM 531-S)

Special Features

- Level control valve by differential pressure with a float in one unit.
- All stainless steel structure suitable for drinking water.
- Mechanical operation independent from any external power source.
- Easy to install – additional pilot piping unnecessary.
- Piston type actuator by differential pressure ensures perfect shutoff at high pressure.
- Available two(2) different types for cooling tower and water tank/reservoir.

Hi-Lo Combi Valve(BALEM 531-S) is a level control valve with internal piping and piston type actuator operated by differential pressure. This unique design ensures perfect shutoff at high pressure. There are two different types to use at water tank (with longer arm) and cooling tower (with shorter arm). The valve is made of stainless steel, which can be used for drinking water and de-mineralized water.

Dimensions

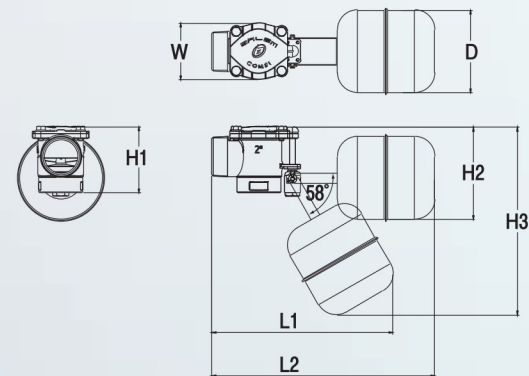
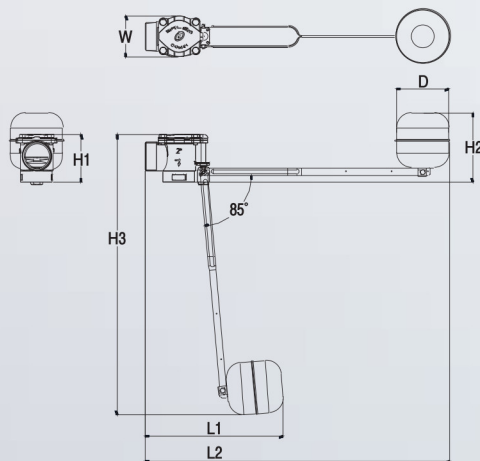

▲ For high & low water level control – Model 531-S HL

SIZE(mm)	H1	H2	H3	W	L1	L2	D(∅)
25A	63	130	563	55	253	600	110
32A	81	135	569	71	266	614	
40A	85	136	573	80	272	619	
50A	94	145	584	81	286	634	
65A	114	156	587	98	306	653	
80A	145	165	609	120	329	677	
100A	167	178	618	145	361	709	

▲ For cooling tower – Model 531-S CT

SIZE(mm)	H1	H2	H3	W	L1	L2	D(∅)
25A	63	118	262	55	238	300	124
32A	81	124	268	71	251	314	
40A	85	128	272	80	257	319	
50A	94	139	282	81	271	334	
65A	114	143	286	98	291	353	
80A	145	164	307	120	314	377	
100A	167	173	316	145	346	409	

Specifications	Hi-Lo Combi Valve (BALEM 531-S)						
Model No.	531-S-025	531-S-032	531-S-040	531-S-050	531-S-065	531-S-080	531-S-100
Size	25A(1")	32A(1¼")	40A(1½")	50A(2")	65A(2½")	80A(3")	100A(4")
Operating Pressure	0.05~0.98 MPa (0.5~10kgf/cm ²)						
Testing Pressure	1.72 MPa (17.5kgf/cm ²)						
End Connections	Male threaded : KSPT(Standard) / N.P.T (Optional : Order) : Flanged (According to Customer Request)						
Media	Water, Oil - Temperature : 0°C ~ 80°C						

Applications

- Substitution for under ground / roof top, low water level ball float control valves.
- Substitution for high and low levels control mechanical valves and electrodes.
- Various types of oil tank float control valves.

Flow Chart

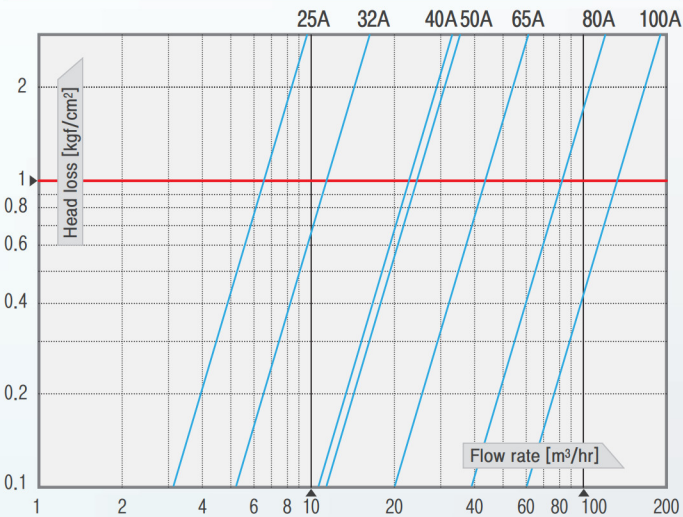

Materials

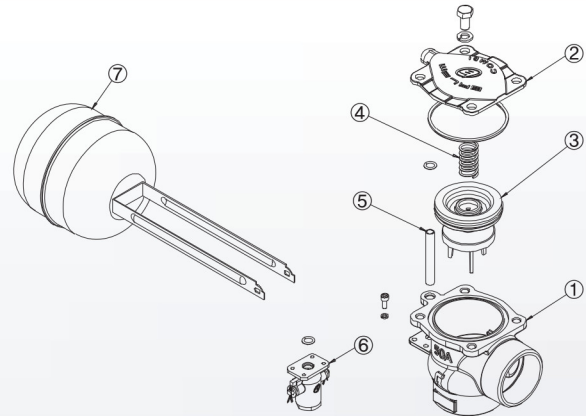

No.	Components	Materials
1	Body	SSC 13
2	Cover	SSC 13
3	Piston Assembly	SSC 13, N.B.R(S,R), Silicon, P.T.F.E
4	Spring	STS 304
5	Pilot Tube	STS 304
6	Pilot Body Assembly	SSC 13, N.B.R, P.T.F.E
7	Float Assembly	STS 304

Typical Applications

Installation Tips!

1. Refer to the standard piping diagram when installing the valve.
2. Install the valve near to the manhole for easy maintenance.
3. Prior to installing the valve, flush the pipe line to clean inside.
4. It is recommended to install an alarm system in the monitoring room to detect an unexpected overflow caused by any other reason except our valve.
5. To prevent waves in the tank while filling the water, a flow induction pipe with syphon braking hole should be installed.
6. When installing, be careful to avoid bending or twisting the arm.
7. Connection flange is an optional item.